

## Instruction and operation manual

# Pressure sensor



Dear Customer,  
thank you for choosing our product.

The operating instructions must be read in full and carefully observed before starting up the device. The manufacturer cannot be held liable for any damage which occurs as a result of non-observance or non-compliance with this manual.

Should the device be tampered with in any manner other than a procedure which is described and specified in the manual, the warranty is cancelled and the manufacturer is exempt from liability.

The device is destined exclusively for the described application.

SUTO iTEC GmbbH offers no guarantee for the suitability for any other purpose. SUTO iTEC GmbH is also not liable for consequential damage resulting from the delivery, capability or use of this device.

## Table of contents

1. Safety instructions.....	4
2. Application.....	6
3. Features.....	6
4. Technical Data.....	7
4.1 General.....	7
4.2 Electrical Data.....	7
4.3 Output-Signals.....	7
4.4 Accuracy .....	7
5. Dimensional drawing.....	8
6. Installation .....	8
6.1 Installation Requirements.....	9
6.2 Installation Procedure .....	9
6.3 Electrical connection .....	9
7. Signal outputs.....	10
7.1 Analog output .....	10
8. Calibration.....	10
9. Maintenance.....	10
10. Disposal or waste.....	10
11. Warranty.....	10

## 1. Safety instructions

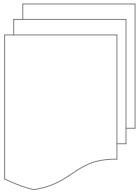

### **Please check if this instruction manual accords to the product type.**

Please observe all notes and instructions indicated in this manual. It contains essential information which have to be observed before and during installation, operation and maintenance. Therefore this instruction manual has to be read carefully by the technician as well as by the responsible user / qualified personnel.

This instruction manual has to be available at the operation site of the pressure sensor at any time. In case of any obscurities or questions, regarding this manual or the product, please contact the manufacturer.



### **WARNING!**

#### **Compressed air!**

**Any contact with quickly escaping air or bursting parts of the compressed air system can lead to serious injuries or even death!**

- Do not exceed the maximum permitted pressure range.
- Only use pressure tight installation material.
- Avoid that persons get hit escaping air or bursting parts of the instrument.
- The system must be pressureless during maintenance work.

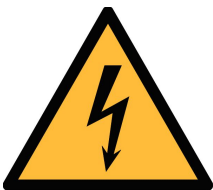

### **WARNING!**

#### **Voltage used for supply!**

**Any contact with energized parts of the product, may lead to a electrical shock which can lead to serious injuries or even death!**

- Consider all regulations for electrical installations.
- The system must be disconnected from any power supply during maintenance work.
- Any electrical work on the system is only allowed by authorized qualified personal.

**WARNING!****Permitted operating parameters!**

**Observe the permitted operating parameters, any operation exceeding this parameters can lead to malfunctions and may lead to damage on the instrument or the system.**

- Do not exceed the permitted operating parameters.
- Make sure the product is operated in its permitted limitations.
- Do not exceed or undercut the permitted storage and operation temperature and pressure.
- The product should be maintained and calibrated frequently, at least annually.

**General safety instructions**

- It is not allowed to use the product in explosive areas.
- Please observe the national regulations before/during installation and operation.

**Remarks**

- It is not allowed to disassemble the product.
- Always use spanner to mount the product properly.

**ATTENTION!****Measurement values can be affected by malfunction!**

**The product must be installed properly and frequently maintained, otherwise it may lead to wrong measurement values, which can lead to wrong results.**

- Do not exceed the maximum operation temperature at the sensors tip.
- Avoid condensation on the sensor element as this will affect the accuracy enormously.

## Storage and transportation

- Make sure that the transportation temperature of the sensor is between -40°C... 100°C.
- For transportation it is recommended to use the packaging which comes with the sensor.
- Please make sure that the storage temperature of the sensor is between -40°C... 100°C.
- Avoid direct UV and solar radiation during storage.
- For the storage the humidity has to be <90%, no condensation.

## 2. Application

The pressure sensor is designed to measure the pressure of compressed air and gases within the permissible operating parameter. These parameters can be found in the technical data section.

The pressure sensor can measure the following values:

The pressure sensor is not developed to be used in explosive areas. For the use in explosive areas please contact the manufacturer.

The pressure sensor is mainly used in compressed air systems in industrial environment.

## 3. Features

- High accurate and affordable industrial pressure sensor.
- Excellent anti-interference capability (EMC, EMI).
- Salt-spray, temperature and humidity test.
- IP67 protection

## 4. Technical Data

### 4.1 General

<b>CE</b>	
Parameters	Standard unit pressure: MPa
Sensor	Thin-film measuring cell
Measuring medium	Air, gas (non corrosive gas)
Measuring range	Depending on model 0... 1.6 MPa or 0... 4.0 MPa
Temperature of the meas. medium	-30°C... 100°C
Operating pressure	2 x F.S.
Burst pressure	2.5 x F.S.
Operating temperature	-30°C... 80°C
Casing material	Stainless steel
Protection class	IP67
Dimensions	See dimensional drawing on the next page
Screwing thread	G 1/4" A (ISO 228/1)
Weight	50 g

### 4.2 Electrical Data

Power supply	24 VDC (12... 32 VDC)
--------------	-----------------------

### 4.3 Output-Signals

Analogue output	4... 20 mA, 2-wire
-----------------	--------------------

### 4.4 Accuracy

Accuracy	± 0.5% F.S.
----------	-------------

### 5. Dimensional drawing

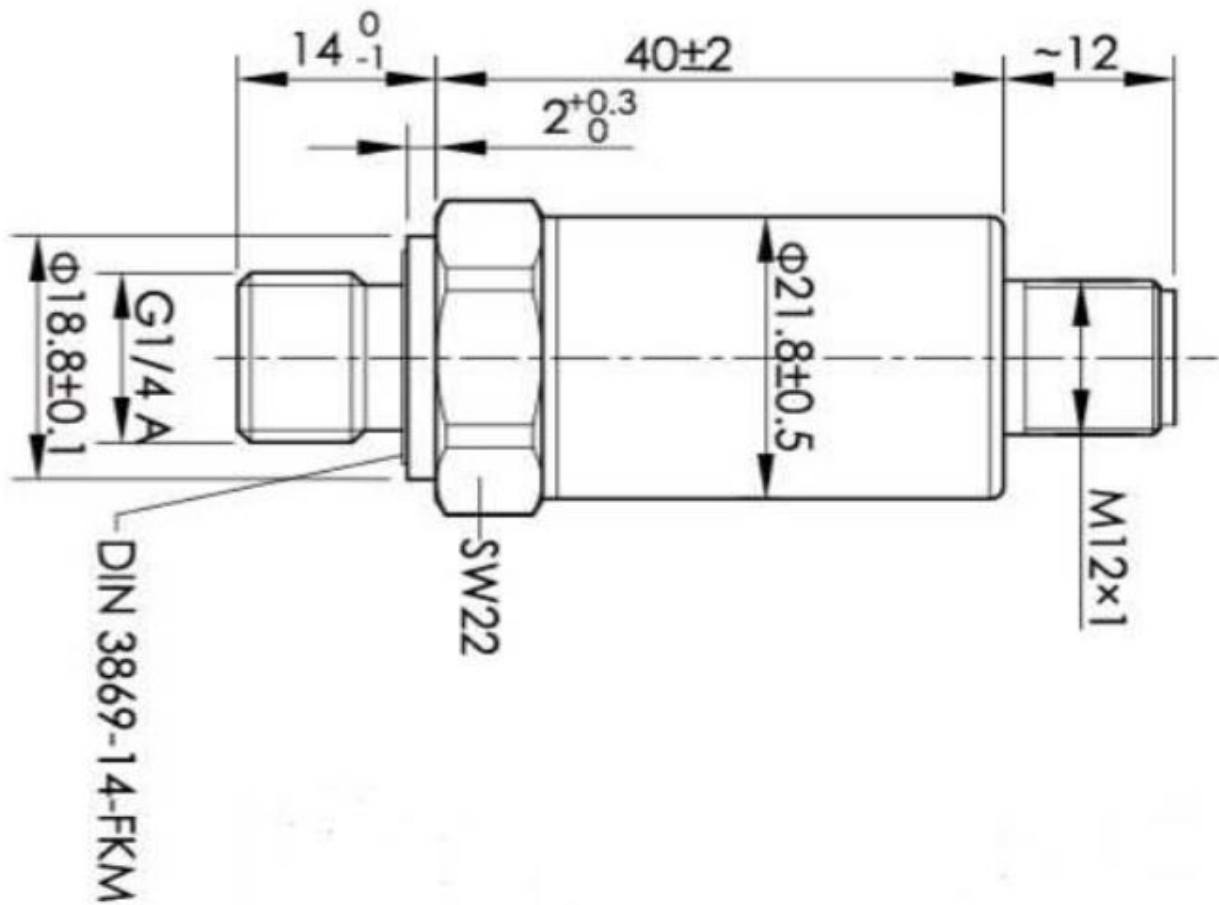

### 6. Installation

Please make sure that all components listed below are included in your package.

Qty	Description	Item No.
1	Pressure sensor (1.6 MPa or 4.0 MPa)	S694 3557/ S694 3558
1	M12 connector	C219 0055
1	Instruction manual	No P/N
1	Calibration certificate	No P/N



**ATTENTION!**

**Wrong measurement is possible, if the sensor is not installed correctly.**



- The sensor is for indoor use only! At an outdoor installation, the sensor must be protected from solar radiation and rain.

## 6.1 Installation Requirements

To install the sensor a ball valve or a nozzle is needed.

- The inner thread has to be G 1/4".

## 6.2 Installation Procedure

The following steps explain the procedure of an appropriate installation

### Installation of the sensor

1. Please screw the pressure sensor tightly to the nozzle.

### Removal of the sensor

1. Please loose unscrew the pressure sensor.

## 6.3 Electrical connection

The cables are connected to the sensor through the M12 connector.

### Connection pins connector plug M12

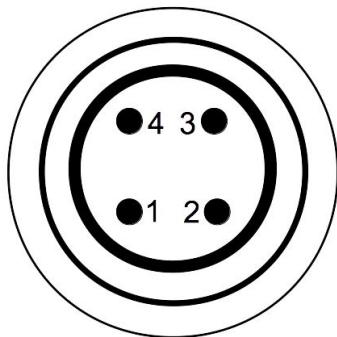

Connection pins  
(view from the  
clamping side)

Pin	Signal	Colour
1	24 VDC	brown
2	+I	white
3	N/A	blue
4	N/A	black

### Legend to pin assignment

24 VDC	24 V power supply
+I	Positive 4...20 mA signal
N/A	Not available



### ATTENTION!

**Do not screw the M12 plug using force. Otherwise, it may damage the connecting pins.**

## 7. Signal outputs

### 7.1 Analog output

The sensor has an analog output range of 4... 20 mA. It is a 2-wire analog output.

## 8. Calibration

It is recommended to calibrate respectively adjust the sensor annually. For this please contact the manufacturer. Please check the date of the last calibration in the attached calibration certificate.

## 9. Maintenance

To clean the sensor and its accessories it is recommended to use a moist cloth only



### **ATTENTION!**

**Do not use isopropyl alcohol to clean the sensor and its accessories !**

## 10. Disposal or waste

Electronic devices are recyclable material and do not belong in the household waste.

The sensor, the accessories and its packings must be disposed according to your local statutory requirements. The disposal can also be carried by the manufacturer of the product, for this please contact the manufacturer.

## 11. Warranty

SUTO iTEC GmbH provides a warranty for this product of 24 months covering the material and workmanship under the stated operating conditions from the date of delivery. Please report any findings immediately and within the warranty time. If faults occurring during the warranty time SUTO iTEC GmbH will repair or replace the defective unit, without charge for labour and material costs but there is a charge for other service such as transport and packing costs.

Excluded from this warranty is:

- Damage caused by:
  - Improper use and non-adherence to the instruction manual.
  - Use of unsuitable accessories.
  - External influences (e.g. damage caused by vibration, damage during transportation, excess heat or moisture).

The warranty is cancelled:

- If the user opens the measurement instrument without a direct request written in this instruction manual.
- If repairs or modifications are undertaken by third parties or unauthorised persons.
- If the serial number has been changed, damaged or removed.

Other claims, especially those for damage occurring outside the instrument are not included unless responsibility is legally binding.

Warranty repairs do not extend the period of warranty.



**ATTENTION!**

**Batteries have a reduced warranty time of 12 month.**

---

## SUTO iTEC GmbH

Werkstr. 2  
79426 Buggingen  
Germany

Tel: +49 (0) 7631 936889-0

Fax: +49 (0) 7631 936889-19

Email: [sales@suto-itec.com](mailto:sales@suto-itec.com)

Website: <http://www.suto-itec.com>

## CS iTEC Co., Ltd.

Room 10, 6/F, Block B, Cambridge Plaza  
188 San Wan Road, Sheung Shui, N.T.  
Hong Kong

Tel: +86 (0) 755 8619 3164

Fax: +86 (0) 755 8619 3165

Email: [sales@cs-itec.asia](mailto:sales@cs-itec.asia)

Website: <http://www.cs-itec.com>